



North Star®

WATER CONDITIONING

NSC40UD1 ULTRA DEMAND WATER SOFTENER

Features

- Designed for better water flow rates and reduced pressure loss. Great for today's large home applications.
- Backlit LCD display - easier to read
- Features patented "Look Ahead" technology for peak performance.
- Quick set-up. Set the time and the hardness and you are done.
- Display shows: Time, Hardness, Regeneration Time, % Remaining Capacity, Current Flow, Total Daily Usage and Average Daily Usage.
- Efficiency selector - Choose either normal or high efficiency mode.
- Diagnostics: Electronic Self Diagnosis, Days in Service, Total Number of Regenerations, Turbine Check and Switches Check
- Gallons / Litres choice
- Selectable fixed recharge frequency
- Adjustable backwash setting

NSC40UD1		
Rated Capacity (Grains @ lb. Salt dose)	11,700 @ 2.3 30,800 @ 8.5 39,000 @ 14.7	
Rated Efficiency ^① (grains/lb @ lb. Salt dose)	5,100 @ 2.3	
Amount of High-Capacity Resin (lbs / cu ft)	56.2 / 1.08	
Resin Tank Nominal Size (in., Dia x height)	9 X 40	
Flow Rate (gpm)	10.0	
Pressure Drop at Service Flow (psi)	14	
Intermittent Flow Rate @ 15 psi ^③	10.2	
Water Supply Max. Hardness (gpg)	110	
Water Supply Max. Clear Water Iron (ppm)	5	
Water Pressure Limits (min./max. Psi)	20 - 100	
Water Temperature Limits. (°F)	40 - 120	
Water Supply Min. Flow Rate (gpm)	3	
Pipe Size	1"	
Regeneration Cycle Flow Rates (gpm)		
Fill (flow to brine tank)	0.3	
Brining	0.22	
Brine Rinse	} (flow to drain)	
Backwash		2.3
Fast Rinse		2.3
Approx. Shipping Wt. Lbs.	120	

NSF/ANSI 44 for specific performance claims as verified and substantiated by test data.

^① Efficiency rating is only at the lowest salt dosage. These softeners were efficiency rated according to NSF/ANSI Standard 44.

Capacity to reduce clear water iron is substantiated by WQA test data.

^③ Intermittent flow rate does not represent the maximum service flow rate used for determining the softeners rated capacity and efficiency. Continuous operation at flow rates greater than the service flow rate may affect capacity and efficiency performance.

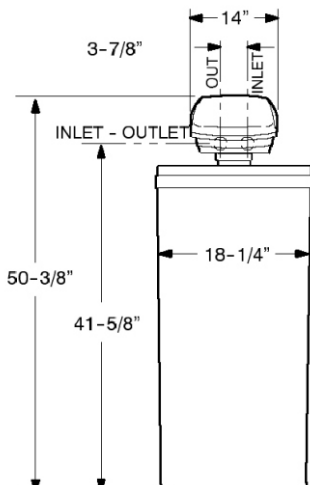

System Tested and Certified by NSF
International against NSF/ANSI Standard
44 for softener performance.



Authorized Dealer